

Auto Synchronizing with other generating sets with prime power or Automatic Mains Failure (AMF) function. When the 6000 series panel is configured as a 6200 control system, it can control up to 8 generating sets operating in parallel on a common bus. The controllers communicate via the RS485 interface and automatically share the active (kW) and reactive (kVAr) load components proportionally. Automatic load sequencing is also performed even if the sets are of different sizes. The load is shared between the generating sets in proportion to their output capability.

In prime power mode the operator selects AUTO on all sets. They start if required and sequence in and out as required by the available load.

When operating in Automatic Mains Failure mode the controller waits for a remote start signal to indicate that the mains have failed. After a time delay the generating sets are started and when the first set closes its' circuit breaker the Generator Load Transfer Contactor closes. The remaining sets synchronize and close their circuit breakers as required. After mains power returns the generating set circuit breakers open and the sets stop after a cool down period. The Mains and Generator Load Transfer Contactors should be electrically and mechanically interlocked to prevent simultaneous operation.

The optional facility of the industry standard Modbus protocol communication interface ensures compatibility with most building management or SCADA/HMI systems.

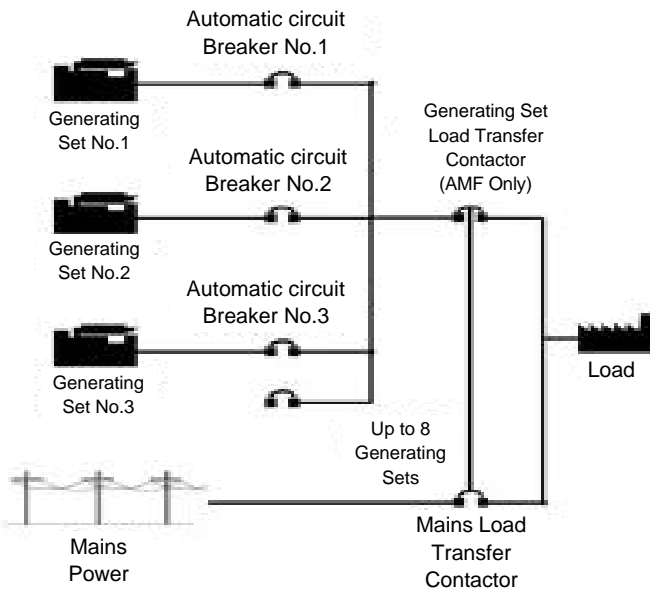

6200 Series



Control Panel



Standard Features

▶ Generating set parameter displays (2 X 4 line LCD display)

AC voltage phase to phase and phase to neutral
(on 3 phases)
AC current (on each of 3 phases)
Frequency
Cos Φ (power factor) average
kW - total + per phase
kVAr - total + per phase
kWh - total
% Voltage difference between bus and generator
Phase shift
Frequency slip
Hours run
Coolant temperature
Lube oil pressure
DC voltage

▶ Bus parameter displays

AC voltage (on a single phase)
AC voltage/frequency within limits indicator

▶ Operator controls

Off/auto/test/run control switch
Emergency stop pushbutton (lockdown)
Membrane keypad with tactile feedback
AC voltage adjust - manual and automatic
Engine speed adjust - manual and automatic

▶ System controls

3 attempt start counter
Cool down delay
Pre-glow delay
Remote start capability
Reverse power relay
Manual synchronizing
Automatic synchronizing
Automatic load sharing control
Automatic loading and unloading ramp controller
Load sequencing control
Static battery charger (5amp) 220/240 Volt AC
Quadrature droop kit

▶ Shutdowns and alarms

High lube oil temperature shutdown
Low coolant temperature shutdown
High coolant temperature shutdown
Low oil pressure shutdown
Overspeed shutdown
Fail to start shutdown
Emergency stop operated
Reverse power shutdown
Overvoltage shutdown
Undervoltage shutdown or alarm
Overfrequency shutdown
Underfrequency shutdown or alarm
Fail to synchronise alarm
Battery undervoltage alarm
Battery overvoltage alarm
Alternator loss of excitation alarm
Spare fault channels, up to 3:
– Low coolant temperature alarm
– Earth fault
– Low fuel level shutdown or alarm
– Low coolant level shutdown

▶ Status indicators

General switch status indicator
Fault log memory
Password security
Interface to remote monitoring package

Optional features

▶ System controls

Volt free contacts for generating set running
R448 regulator (required)
Electronic governor (required)
Droop engine control module

▶ Shutdowns and alarms

Earth fault shutdown
High fuel level alarm

TEL.:0044-2893 359938

FAX: 0044-2893 328897

Website:www.marapco.com

N. Ireland - UK

Manufactured By: FG Wilson (Engineering) Ltd

Old Glenarm Road, Larne, County Antrim BT40 1EJ

Northern Ireland, United Kingdom

Tel: +44 (0) 28 2826 1000 Fax: +44 (0) 28 2826 1111

