

Modular Acoustic Enclosures

The **MARAPCO** fully weatherproof sound attenuated (SA) enclosure reduces sound levels to comply with the stage 2 levels of the European Community regulations 2000/14/EC which became effective from 3 January 2006.

P13.5-4 - P22-4 Range



CAE

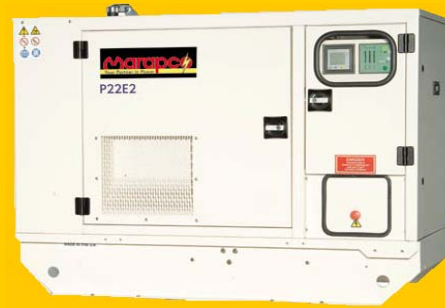

CAL

YOUR PARTNER IN POWER

Highly Corrosion Resistant Construction

- ▶ Stainless steel locks.
- ▶ Black zinc die cast hinges on gullwing doors tested and proven to withstand extremely corrosive conditions.
- ▶ Zinc plated or stainless steel fasteners and hinges.
- ▶ Body made from steel components pre-treated with zinc phosphate prior to polyester powder coating.

Highly Corrosion Resistant Construction

- ▶ Black zinc die cast hinges tested and proven to withstand extremely corrosive conditions.
- ▶ Zinc passivated and stainless steel fasteners.
- ▶ Body made from sheet steel components with polyester powder coating at 200°C (392°F).

Excellent Access for Maintenance

- ▶ Top hung gullwing doors.
- ▶ Hinged and lockable end panels.
- ▶ Radiator fill access through radiator end panel.
- ▶ Lube oil drain piped to exterior of the canopy.

Excellent Access for Maintenance

- ▶ Vertically hinged side doors allowing 180° opening rotation.
- ▶ Front and rear "lift-off" access panels.
- ▶ Radiator fill access through cover in canopy roof.
- ▶ Lube oil drain and radiator drain.

Security and Safety

- ▶ Perspex control panel viewing window in a lockable access door.
- ▶ Emergency stop button mounted on canopy exterior.
- ▶ End panels secured by internal latches with safety retainer.
- ▶ Cooling fan and battery charging alternator fully guarded.
- ▶ Fuel fill and battery can only be reached via lockable access doors.
- ▶ Exhaust silencing system enclosed for operator safety.

Security and Safety

- ▶ Perspex control panel viewing window in a lockable access door.
- ▶ Emergency stop button mounted on canopy exterior.
- ▶ Cooling fan and battery charging alternator fully guarded.
- ▶ Fuel fill and battery can only be reached via lockable access doors.
- ▶ Exhaust silencing system enclosed for operator safety.

Transportability

- ▶ Tested and certified single point lifting facility.

Transportability

- ▶ Lifting points on baseframe.

Optional Features

- ▶ Lockable vandal proof control panel cover in place of window.

Sound Pressure Levels (dBA)

		50 Hz at 1500 RPM						60 Hz at 1800 RPM							
		15 m (50 ft)		7 m (23 ft)		1 m (3 ft)		15 m (50 ft)		7 m (23 ft)		1 m (3 ft)			
Generating Set Model	LWA	75% Load	100% Load	75% Load	100% Load	75% Load	100% Load	75% Load	100% Load	75% Load	100% Load	75% Load	100% Load		
3 Phase Models															
P13.5-4 (CAE)	Prime	90.0	59.7	61.0	65.7	67.0	75.4	76.7	Prime	63.1	63.2	67.3	69.2	77.2	79.4
	Standby	90.0	60.1	61.5	66.1	67.5	75.8	77.2	Standby	61.7	64.0	67.7	70.0	77.7	80.2
P18-4 (CAE)	Prime	91.0	58.6	60.1	64.6	66.1	73.5	74.9	Prime	60.7	61.6	66.7	67.6	75.5	76.4
	Standby	91.0	59.0	60.7	65.0	66.7	73.8	75.5	Standby	60.9	62.1	66.9	68.1	75.7	76.8
P22-4 (CAE)	Prime	91.0	59.5	61.6	65.5	67.6	74.3	76.4	Prime	61.1	62.5	67.1	68.5	75.9	77.2
	Standby	91.0	60.1	62.6	66.1	68.6	74.9	77.5	Standby	61.5	63.3	67.5	69.3	76.2	78.0
3 Phase Models															
P13.5-4 (CAL)	Prime	86.0	52.7	53.9	58.7	59.9	70.8	71.9	Prime	55.0	56.0	61.0	62.0	72.3	74.0
	Standby	86.0	53.1	54.5	59.1	60.5	71.1	72.4	Standby	55.3	56.4	61.3	62.4	72.7	74.6
P18-4 (CAL)	Prime	91.0	55.6	56.0	61.6	62.0	72.8	73.4	Prime	58.4	59.7	64.4	65.7	75.3	77.2
	Standby	91.0	55.7	56.2	61.7	62.2	72.9	73.7	Standby	58.7	60.4	64.7	66.4	75.8	78.1
P22-4 (CAL)	Prime	91.0	55.8	56.4	61.8	62.4	73.2	74.2	Prime	59.0	60.9	65.0	66.9	76.1	78.7
	Standby	91.0	56.0	56.7	62.0	62.7	73.4	74.7	Standby	59.5	62.0	65.5	68.0	76.9	80.1

Levels in accordance with European Noise Directive (2000/14/EC)

CAE

CAL

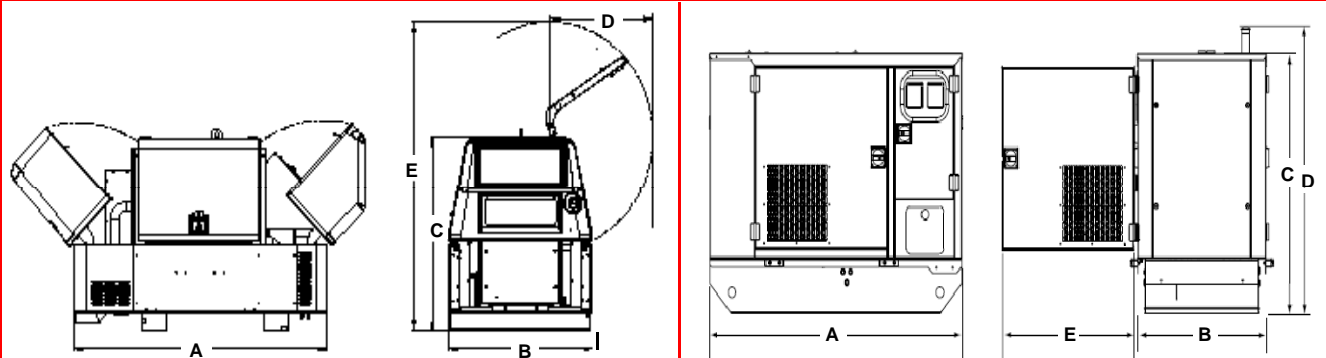

Dimensions and Weights

Generating Set Model		A mm (in)	B mm (in)	C mm (in)	D mm (in)	E mm (in)	Fuel Capacity L (US Gal)	Weight Kg (lb)
3 Phase Models								
P13.5-4	CAE	1593 (62.7)	900 (35.4)	1275 (50.2)	840 (33.1)	1878 (73.9)	45.0 (12.0)	580 (1279)
P18-4	CAE	1593 (62.7)	900 (35.4)	1275 (50.2)	840 (33.1)	1878 (73.9)	45.0 (12.0)	641 (1413)
P22-4	CAE	1593 (62.7)	900 (35.4)	1275 (50.2)	840 (33.1)	1878 (73.9)	45.0 (12.0)	654 (1442)
P13.5-4	CAL	1684 (66.3)	860 (33.9)	1253 (49.3)	1385 (54.5)	880 (34.6) †	45 (12.0)	645 (1422)
P18-4	CAL	1684 (66.3)	860 (33.9)	1253 (49.3)	1385 (54.5)	880 (34.6) †	45 (12.0)	706 (1556)
P22-4	CAL	1684 (66.3)	860 (33.9)	1253 (49.3)	1385 (54.5)	880 (34.6) †	45 (12.0)	719 (1585)

Note: Net Weight with lube oil, no coolant, no fuel.

†Clearance required both sides.

TEL./FAX.: 0044 2893 355674
 Website: www.marapco.com
 N. Ireland - UK



Dec-08

In line with our policy of continuous product development, we reserve the right to change specification without notice.

Made in UK